

NUMBER 332057

©1965 BY AMP INCORPORATED. ALL RIGHTS RESERVED. AMP PRODUCTS COVERED BY PATENTS AND/OR PATENTS PENDING. APPROVED PER GOVT CONTRACT NO.

REVISIONS				
SYM	ZONE	DESCRIPTION	DATE	APPROVAL
A		TIN PL WAS SILVER PL .0002 MIN EXTN	7/8/65	RHW
B		REVISED	RF-554 8 th 2-20-68	RHW
C		REVISED PER ECN RF9-78	PI 4-7-68	BHW

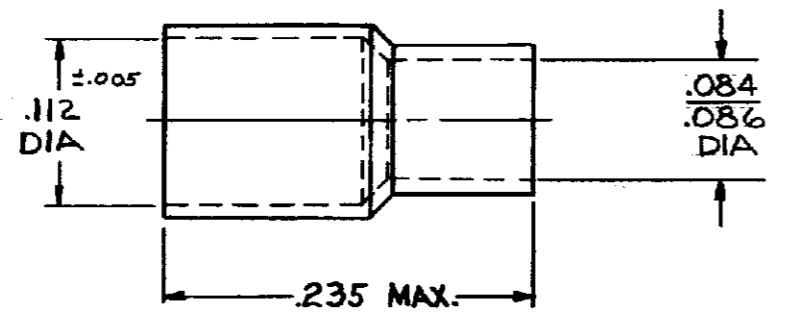

QTY REQD	NOMENCLATURE OR DESCRIPTION	PART OR IDENTIFYING NO.	MATERIAL AND PLATING
1	FERRULE	I-332057-0	COPPER (QQ-C-576) TIN PL (MIL-T-10727)

LOC	PRINT DIST	WIRE SIZE
AJ	16	RG-178 #196/0

UNLESS OTHERWISE SPECIFIED DIMENSIONS ARE IN INCHES TOLERANCES ON		
FRACTIONS ± 1/64	DECIMALS ± .008	ANGLES ± 5°
MATERIAL SEE TABLE		
HEAT TREAT #		
FINISH SEE TABLE		

SIGNATURE		DATE
DR <i>T. DePinto</i>		6-23-65
CHK <i>RHWolfe</i>		7/23/65
DESIGN ENGR		
APPR <i>Ball</i>		4/24/65
DESIGN APPD		
OTHER APPD		

AMP INCORPORATED HARRISBURG, PENNSYLVANIA	
NAME SUB-MINIATURE COAXIAL FERRULE	
CODE IDENT NO 00779	SIZE NUMBER B 332057
SCALE 10-1	WT CALC ACTUAL SHEET 1 OF 1